

TM02 8333 0405

Dimensional sketches

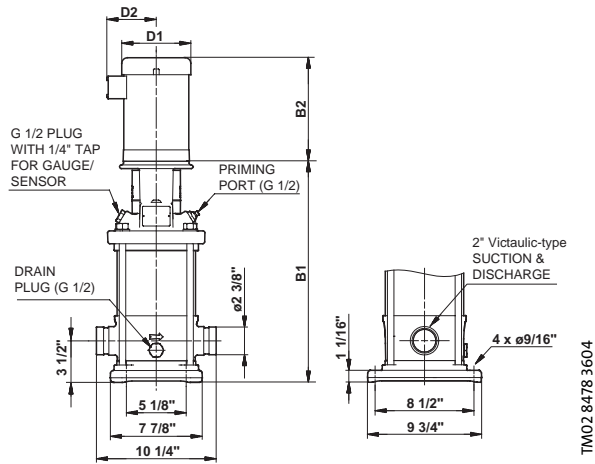

Dimensions and weight

Pump Type	HP	PH	Voltage	Frame Size	CRT				Ship Wt.	CRTE			
					Dimensions					Dimensions			
					B1	D1	D2	B1+B2		D1	D2	B1+B2	Ship Wt.
CRT(E) 16-2	5	1	208-230	182TC	18 1/4	10 5/8	7 1/2	33 5/8	147	-	-	-	-
		3	208-230/460	182TC	18 1/4	8 5/8	6	34 1/4	115	8 3/4	7 1/2	33 1/8	124
CRT 16-3	7 1/2	1	208-230	213TC	18 1/4	10 1/4	7 1/2	33 5/8	161	-	-	-	-
		3	208-230/460	213TC	18 1/4	10 1/4	8 1/8	33 5/8	131	-	-	-	-
CRT(E) 16-4	7 1/2	1	208-230	213TC	23 1/8	10 1/4	7 1/2	38 1/2	182	-	-	-	-
		3	208-230/460	213TC	23 1/8	10 1/4	8 1/8	38 1/2	151	8 3/4	7 1/2	38 3/4	127
CRT(E) 16-5	10	1	230	213TC	23 1/8	10 1/4	10 3/8	39	226	-	-	-	-
		3	208-230/460	213TC	23 1/8	10 1/4	7 1/2	38 1/2	181	8 3/4	7 1/2	38 3/4	135
CRT 16-6	15	3	208-230/460	254TC	26 5/8	10 1/4	8 3/4	43 1/4	242	-	-	-	-
CRT 16-7	15	3	208-230/460	254TC	26 5/8	10 1/4	8 3/4	43 1/4	245	-	-	-	-
CRT 16-8	15	3	208-230/460	254TC	35	10 1/4	8 3/4	51 5/8	246	-	-	-	-
CRT 16-10	20	3	230/460	284TSC	35	13	9 1/2	54 3/4	270	-	-	-	-
CRT 16-12	25	3	230/460	284TSC	42 1/8	13	9 1/2	61 7/8	337	-	-	-	-