

TM02 8332 0405

Dimensional sketches

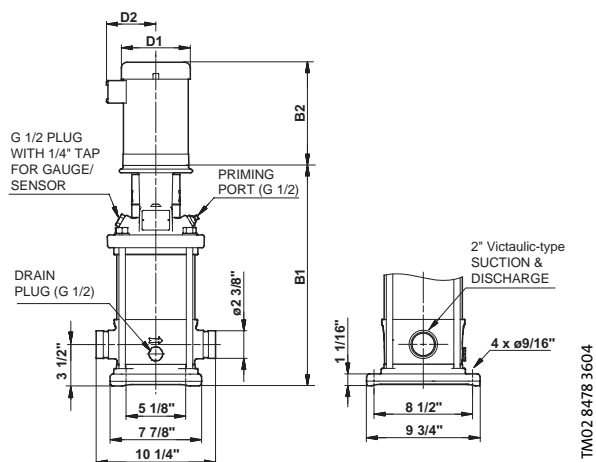

Dimensions and weight

Pump Type	HP	PH	Voltage	Frame Size	CRT				Ship Wt.	CRTE			Ship Wt.
					Dimensions					D1	D2	B1+B2	
					B1	D1	D2	B1+B2					
CRT(E) 8-1*	3/4	1	115/208-230	56C	14 1/8	6 1/4	5	24 1/8	68	5 5/8 *	5 5/8 *	23 3/8*	53*
		3	208-230/460	56C	14 1/8	6 1/4	5	23 1/2	61	-	-	-	-
CRT(E) 8-2	1 1/2	1	115/208-230	56C	14 1/8	7 1/4	5 3/4	25 7/8	82	5 5/8	5 5/8	23 3/8	56
		3	208-230/460	56C	14 1/8	7 1/4	5 3/4	24 7/8	70	7 1/8	6 5/8	25 1/2	65
CRE 8-3	3	1	115/208-230	56C	15 1/4	8 5/8	6 7/8	29 3/4	119	-	-	-	-
		3	208-230/460	56C	15 1/4	8 5/8	6 7/8	27 3/4	100	-	-	-	-
CRT(E) 8-4	3	1	115/208-230	56C	15 1/4	8 5/8	6 7/8	29 3/4	119	-	-	-	-
		3	208-230/460	56C	15 1/4	8 5/8	6 7/8	27 3/4	100	7 1/8	6 5/8	28 1/8	81
CRT 8-5	5	1	208-230	56C	19 1/2	10 5/8	7 1/2	34 7/8	150	-	-	-	-
		3	208-230/460	56C	19 1/2	8 5/8	6	35 1/2	118	-	-	-	-
CRT(E) 8-6	5	1	208-230	182TC	19 1/2	10 5/8	7 1/2	34 7/8	155	-	-	-	-
		3	208-230/460	182TC	19 1/2	8 5/8	6	35 1/2	122	8 3/4	7 1/2	34 3/8	116
CRT 8-8	7 1/2	1	208-230	182TC	24 3/8	10 1/4	7 1/2	39 3/4	183	-	-	-	-
		3	208-230/460	182TC	24 3/8	10 1/4	8 1/8	39 3/4	152	-	-	-	-
CRT(E) 8-10	7 1/2	1	208-230	182TC	24 3/8	10 1/4	7 1/2	39 3/4	187	-	-	-	-
		3	208-230/460	182TC	24 3/8	10 1/4	8 1/8	39 3/4	156	8 3/4	7 1/2	40	132
CRT(E) 8-12	10	1	230	182TC	32 3/4	10 1/4	10 3/8	48 5/8	234	-	-	-	-
		3	208-230/460	182TC	32 3/4	10 1/4	7 1/2	48 1/8	189	8 3/4	7 1/2	48 3/8	140
CRT 8-14	15	3	208-230/460	254TC	32 3/4	10 1/4	8 3/4	49 3/8	250	-	-	-	-
CRT 8-16	15	3	208-230/460	254TC	35 1/8	10 1/4	8 3/4	51 3/4	265	-	-	-	-

* 1-phase CRTE 8-1 requires 1.0 HP MLE motor.