



# ITT

Wastewater

## Goulds Pumps

1GD Submersible  
Grinder Pump

Dual Seal with Optional  
Seal Sensor Probe



 **GOULDS PUMPS**

Goulds Pumps is a brand of ITT  
Residential and Commercial Water.

[www.goulds.com](http://www.goulds.com)

*Engineered for life*

### FEATURES

- Single phase pumps now have built-in overload protection. See control panel note on page 3.
- **Impeller:** Silicon bronze, multi-vane semi-open, with pump-out vanes for mechanical seal protection. Balanced for smooth operation.
- **Grinder Cutter System:** The anti-roping design, hardened cutter is keyed to the motor shaft for positive drive. The cutter ring is specially designed to be reversed when the first side wears out thus doubling its life and reducing maintenance costs. The cutter system is designed and tested to pass items found in normal wastewater.
- **Casing:** Heavy duty cast iron, volute type for maximum efficiency. Use with A10-12 guide rail system for ease of installation and maintenance.
- **Dual Mechanical Seals:** Silicon carbide vs. silicon carbide outer seal and ceramic vs. carbon inner seal, stainless steel metal parts, BUNA-N elastomers. Upper and lower shaft seals are positioned independently and are separated by an oil-filled chamber. Optional Silicon/Tungsten Carbide outer seal available.
- **Optional Seal Sensor Probe:** Located in oil-filled chamber. If pumpage should begin to leak past lower seal it indicates to pump control panel a fault has occurred. Requires optional Seal Fail Circuit in the control panel.
- **Fasteners and Pipe Plugs:** 300 series stainless steel.

### AGENCY LISTINGS



Tested to UL 778 and CSA 22.2 108 Standards  
By Canadian Standards Association  
File #LR38549

Goulds Pumps is ISO 9001 Registered.

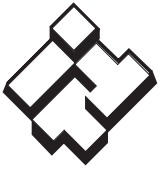

# ITT

## GOULDS PUMPS Wastewater

### APPLICATIONS

Designed for high head sewage applications where a gravity system is not practical. Ideal for pressure sewage systems.

### SPECIFICATIONS

#### Pump:

- Solids handling capabilities: 3" maximum.
- Discharge: 1 1/4" NPT removable flange.
- Capacities: up to 46 GPM.
- Total heads: up to 106 feet TDH.

#### Motor:

- 2 HP, 3450 RPM, 60 Hz
- Class "F" insulation
- Rated for continuous duty fully submerged
- Max. Fluid Temperature: 104° F continuous duty, 140° F intermittent duty

#### Single Phase:

- 208 or 230 volt
- Built-in, auto reset, on-winding motor overload

#### Three Phase:

- 200, 230, 460 or 575 volt
- Class 10 ambient compensated, overload protection required in control panel.

### MOTORS

- Fully submerged in oil-filled chamber. High grade turbine oil surrounds motor for more efficient heat dissipation, permanent lubrication of bearings and mechanical seal for complete protection against outside environment.

#### ■ Class F insulation.

- **Single phase:** 2 HP, 208 or 230 volt, 60 Hertz, 3450 RPM, 14/4 power cord. Motor has built-in overload with automatic reset. Start capacitor, run capacitor and starting relay are required and will be located in the control panel. See "Recommended Control Panels" in chart on this bulletin.

- **Three phase:** 2 HP, 200, 230, 460 or 575 V, 60 Hz, 3450 RPM. 14/4 STOW. Overload protection must be provided in starter unit.

- **Designed for Continuous Operation:** Pump ratings are within the motor manufacturer's recommended working limits and can be operated continuously without damage when fully submerged.

- **Bearings:** Upper and lower heavy duty ball bearing construction for precision positioning of parts and to carry thrust loads.

- **Power (Sensor) Cables:** Severe duty rated, oil and water resistant. Epoxy seal on motor end provides secondary moisture barrier in case of outer jacket damage and to prevent oil wicking. 20 foot standard with optional lengths available.

- **O-ring:** Assures positive sealing against contaminants and oil leakage.

- **Shaft:** 300 series stainless steel, keyed design, short overhang for minimum shaft deflection.

- Pump is capable of running dry without damage to mechanical components.

### NOMENCLATURE DESCRIPTION

#### 1st, 2nd and 3rd Characters – Discharge Size and Type

1GD = 1 1/4" discharge, grinder, dual seal

#### 4th Character – Mechanical Seals

5 = silicon carbide/silicon carbide/BUNA – lower seal and carbon/ceramic/BUNA – upper seal (standard)

3 = silicon carbide/tungsten carbide/BUNA – lower seal and carbon/ceramic/BUNA – upper seal (optional)

#### 5th Character – Cycle/RPM

1 = 60 Hz/3500 RPM      5 = 50 Hz/2900 RPM

#### 6th Character – Horsepower

G = 2 HP

#### 7th Character – Phase/Voltage

1 = single phase, 230 V      5 = three phase, 575 V  
 2 = three phase, 200 V      6 = three phase, 380 V  
 3 = three phase, 230 V      8 = single phase, 208 V  
 4 = three phase, 460 V

#### 8th Character – Impeller Diameter

A = 5 5/8", Standard      C = 4 3/4"  
 B = 5 1/4"      D = 4 1/4"

#### 9th Character – Cord Length (Power and Sensor)

A = 20' (standard)      F = 50'      J = 100'  
 D = 30'      G = 75'

#### 10th Character – Options

S = Seal fail, moisture sensing circuit<sup>1</sup>

E = Epoxy paint

#### Last Character – Option

H = Pilot duty thermal sensors<sup>1</sup>

<sup>1</sup>These options add a 2-wire or 4-wire sensor cord to the pump and require optional control panel circuits to operate. See panel options on control panel bulletin BCP5.



# ITT

## GOULDS PUMPS Wastewater

### MODEL AND MOTOR INFORMATION

ORDER NO.	HP	PHASE	VOLTS	RPM	MAXIMUM AMPS	LOCKED ROTOR AMPS	KVA CODE	FULL LOAD EFFICIENCY %	RESISTANCE		POWER CORD	WEIGHT LBS.
									START	LINE-LINE		
1GD51G1AA	1	1	230	3450	15.5	120.0	P	79.0	1.37	0.62	14/4 STOW	110
1GD51G8AA			208		17.5							
1GD51G2AA	2	3	200	3450	14.0	44.8	J	81.0	NA	1.8	20' LONG	105
1GD51G3AA			230		12.0							
1GD51G4AA			460		6.0	18.7	J	83.2				
1GD51G5AA			575		4.8							

### FEATURES (continued)

Effective with December 2005 (M05)  
Date Codes -

Single-Phase 1GD Pumps Contain a Built-in, Auto Reset Overload.

### Important Control Panel Requirements and Notes:

- 1) See panel bulletin BCP5 for other available options.
- 2) These pumps require a magnetic contactor, start and run capacitors and a starting relay in the control panel.
- 3) CP-1GDB Capacitor packs with starting relays are available on product bulletin BCPCAP. They are for certified panel shops to "build" into a custom panel. Field installing capacitor packs into a S10020 or D10020 will negate the UL listing on that panel and is therefore not permissible.

Pump Order No.	Pump Seal Fail Circuit	Voltage / Phase	Recommended Control Panel	
			Simplex	Duplex
1GD51G1A_	NO	230 / 1	S1GD2	D1GD2
1GD51G8A_	NO	208 / 1	S1GD2	D1GD2
1GD51G1A_S	YES	230 / 1	S1GD2H	D1GD2J
1GD51G8A_S	YES	208 / 1	S1GD2H	D1GD2J

### MATERIALS OF CONSTRUCTION

Item No.	Part Name		Material				
1	Impeller, multi-vane		1179				
2	Castings		1003				
3	Shaft-keyed		300 Series SS				
4	Fasteners		300 Series SS				
5	Ball bearings		Steel				
6	Power cable		STOW, 20 feet				
7	O-ring		BUNA-N				
8	Outer Mech. Seal	No.	Service	Rotary	Stationary	Elastomers	Metal Parts
	OPT	10K22	Heavy duty	Silicon Carbide	Tungsten Carbide	BUNA-N	300 Series SS
	STD	10K28	Mild abrasives	Silicon carbide		BUNA-N	300 Series SS
Material Code			Engineering Standard				
1003			Cast iron — ASTM A48 Class 30				
1179			Silicon bronze — ASTM C87600				

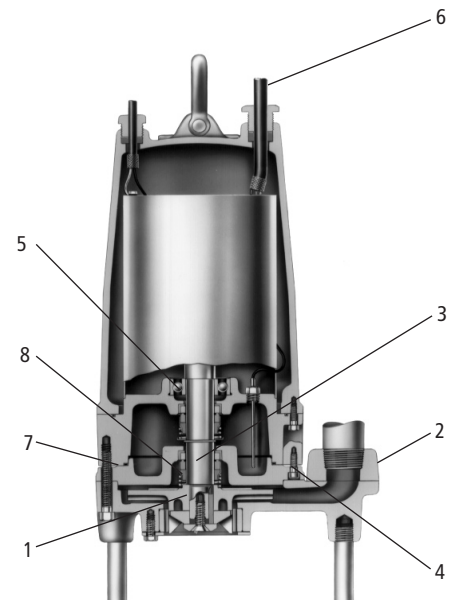



# ITT

## Wastewater

### APPLICATION DATA

Maximum Solid Size	N/A
Minimum Casing Thickness	5/16"
Casing Corrosion Allowance	1/8"
Maximum Working Pressure	50 PSI
Maximum Submergence	50 feet
Minimum Submergence	Fully submerged for continuous operation 6" below top of motor for intermittent operation
Maximum Environmental Temperature	40°C (104°F) continuous operation 60°C (140°F) intermittent operation

### CONSTRUCTION DETAILS

Power Cable – Type	14/3, type STOW: single phase 14/4, type STOW: three phase 14/4, type STOW: all three phase
Sensor Cable – Type	16/2, type SJTOW: heat sensor or seal fail only 18/4, type SJTOW: seal/heat sensor
Motor Cover	Gray Cast Iron – ASTM A48 Class 30
Bearing Housing	Gray Cast Iron – ASTM A48 Class 30
Seal Housing	Gray Cast Iron – ASTM A48 Class 30
Casing	Gray Cast Iron – ASTM A48 Class 30
Impeller	Cast Bronze – ASTM B584 C87600
Motor Shaft	AISI 300 Series Stainless Steel
Motor Design	NEMA 56 Frame, oil filled with Class F Insulation
Optional: Motor Seal Fail (Moisture) Detection	Seal fail sensor in an oil-filled seal chamber. Connect to an optional relay in control panel.
Optional: Motor Thermal Protection 1Ø and 3Ø	Normally closed on-winding thermostats open at 275° F (135° C) and close at 112° F (78° C). Require terminal connections in the control panel.
Motor Overload Protection	<b>Single Phase:</b> Built-in, auto reset overload. <b>Three Phase:</b> Requires ambient compensated, Class 10 protection in the control panel.
External Hardware	300 Series stainless steel
Impeller Type	Semi-open with pump out vanes on back shroud
Cutter	Two blades; type 440C stainless steel
Oil Capacity – Seal Chamber	1.5 quarts
Oil Capacity – Motor Chamber	4.5 quarts

### STANDARD PARTS

Ball Bearing – Upper	Single row ball – SKF™ 6203-2Z
Ball Bearing – Lower	Single row ball – SKF™ 6206-2Z
Mechanical Seals – Standard	Carbon/Ceramic – Upper Silicon Carbide/Silicon Carbide – Lower
Mechanical Seals – Optional	Silicon Carbide/Tungsten Carbide – Lower
O-Ring – Stuffing Box	BUNA-N, AS 568A-256
O-Ring – Motor Cover	BUNA-N, AS 568A-166



Goolds Pumps and the ITT Engineered Blocks Symbol are registered trademarks and tradenames of ITT Corporation.

SPECIFICATIONS ARE SUBJECT TO CHANGE WITHOUT NOTICE.

**B1GD August, 2006**  
© 2006 ITT Corporation

*Engineered for life*

### DIMENSIONS

(All dimensions are in inches. Do not use for construction purposes.)

